

Recommendations for Risers and Solutions for Services

By Craig Fisher, P.E.
Technical Director

Following many years of careful study and evaluations of countless installations, Uni-Bell's Fittings Task Group has developed new and improved recommendations for risers and service connections. With the publishing of the fourth edition of the Handbook and a new technical bulletin on risers, Uni-Bell is stepping up its efforts to pass on this knowledge to the engineering and utility contracting communities.

EXCESSIVE LATERAL BENDING

The Fittings Task Group identified a common and understandable situation. Refer to Figure 1.

This pair of two-dimensional sketches, at first glance, appears to result in a lateral that will form a ninety-degree angle with the sanitary sewer main. But appearances can be deceiving! The photographs in Figure 2 provide a simple – yet very effective – way of communicating the deficiency in Figure 1.

These photographs show the lateral assembled as detailed in Figure 1 and without any longitudinal bending. The service has been laid to a slight grade of two degrees. Note that the lateral is definitely not square with the sewer main. Unfortunately, this lack of squareness is usually “corrected” with the “field adjustment” shown in Figure 3.

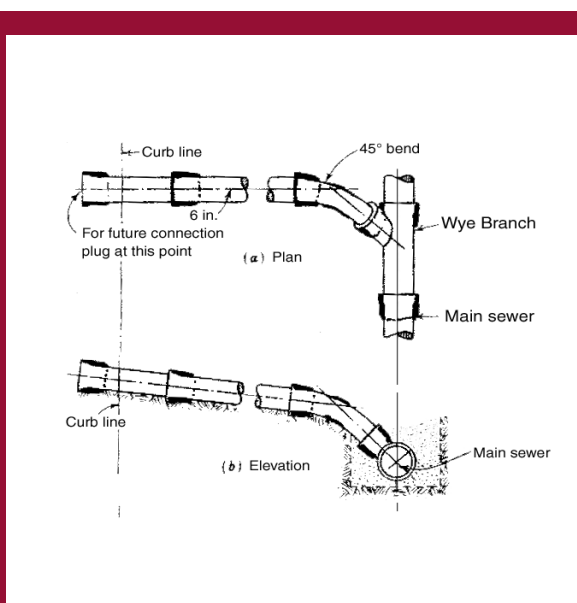

Figure 1
When a 45° bend and a wye are used, the lateral will not form a ninety degree angle with the main line.



Figure 2
These photographs show a lateral installed with a 45° bend and a wye as sketched in Figure 1.

This type of “field adjustment” puts an extraordinary amount of stress on the 45-degree bend and the wye. The photos shown in Figure 4 show a close-up of the fittings when the lateral is excessively bent. The quote by Archimedes, “Give me a lever long enough ... and I can singlehandedly move the world,” has a corollary when installing service connections. It goes: “Give me a length of PVC sewer pipe long enough and I can singlehandedly crack a service-connection fitting!”

Using an additional elbow, as shown in Figure 5, solves this problem.

The extra degree of freedom provided by the sketch in Figure 5 allows the contractor to install the service

connection without having to bend the lateral. Straight alignment is a key criterion for a successful design and installation.

UNIFORM COMPACTION

A second point raised during the service connection and riser discussions concerned differential compaction above and below the service connection and lateral. The embedment material above the fittings and the lateral is more accessible than the support material below. As a result, a far greater amount of compactive effort may be applied above the service compared to the material underneath. The compactive effort above the lateral may even cause local deformation (with their resulting stresses) in the ser-

The quote by Archimedes, “Give me a lever long enough ... and I can singlehandedly move the world,” has a corollary when installing service connections. It goes: “Give me a length of PVC sewer pipe long enough and I can singlehandedly crack a service-connection fitting!”



Figure 3
A typical "field adjustment" is photographed here. This "adjustment" produces an extraordinary amount of stress on the fittings.



Figure 4
Close-up photographs of the fittings when over-stressed.

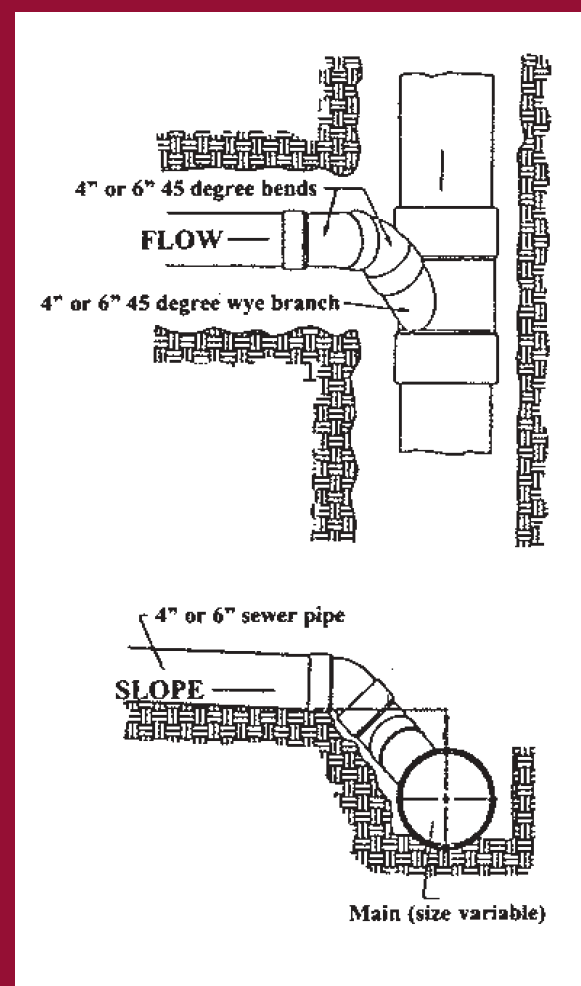

Figure 5
The additional fitting shown in this sketch allows the lateral to be laid square to the main without overstressing the fittings.

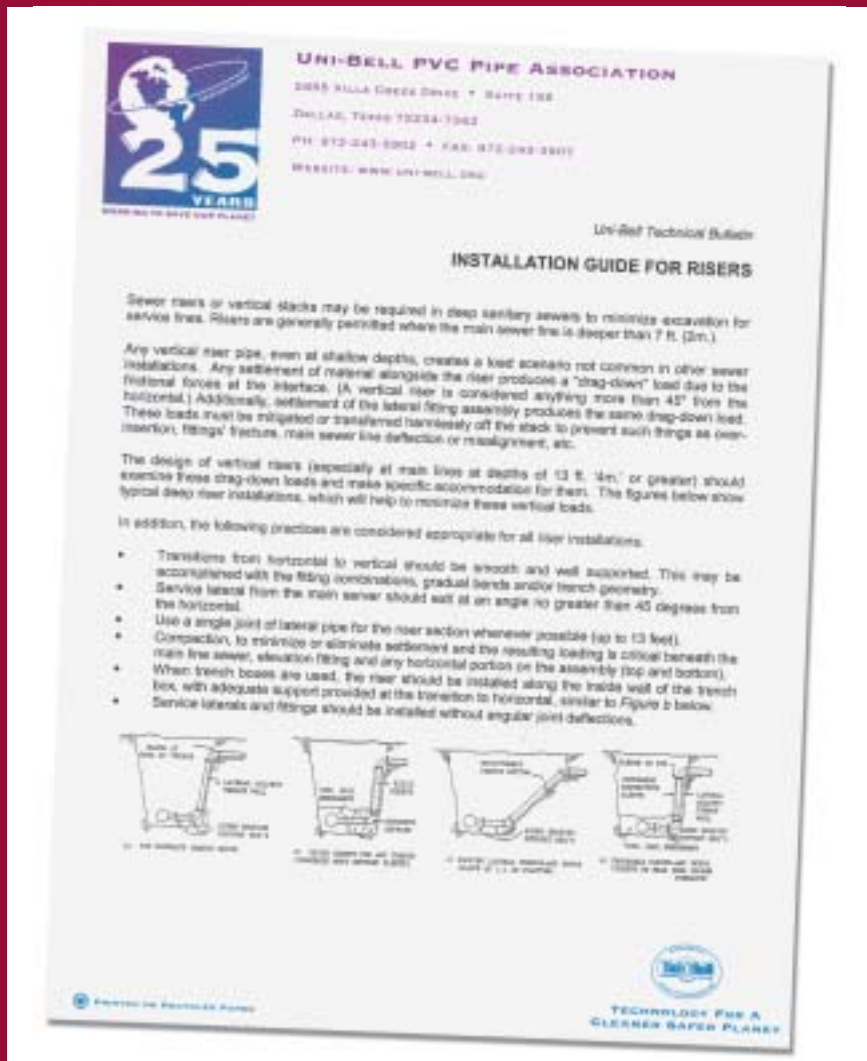

Figure 6
Newly published Technical Bulletin provides updated recommendations for risers.

vice where there is poor longitudinal support. The second criterion for a successful design and installation is to have firm support for the fittings and the lateral and to have the same proctor density above and below the service.

option (d) shown at the bottom of the Technical Bulletin provide additional provisions for drag-down forces. Option (b) addresses it by requiring a rigid sleeve with enough strength to resist column buckling. The drag-down loads are transferred to the trench bottom by a concrete block poured at the

Straight alignment is a key criterion for a successful design and installation. The second criterion is to have firm support for the fittings and the lateral.

NEW RISER TECHNICAL BULLETIN

Having reviewed some of the background discussions, it is now time to present the final product. Please see "Installation Guide for Risers" shown as an inset in Figure 6 (This bulletin may be downloaded from Uni-Bell's Website.)

Note that in all cases, the riser is installed against the trench wall. This reduces the drag-down loads from soil settlement in the trench. Option (b) and

base of the rigid sleeve. Option (d) takes a different tact. It addresses the drag-down forces by providing a crushable sleeve that moves with the settlement. The sleeve is typically an unlined corrugated polyethylene pipe, which can move and settle without transferring the loads to the riser.

The Fittings Task Group is commended for all their effort. Their updated recommendations will better ensure trouble-free operation of your sanitary sewer services.